

DESCRIPTION

The ModMAG[®] M1000 Electromagnetic Flow Meter is the result of years of research and field use of electromagnetic flow meter technology. Designed, developed and manufactured under strict quality standards, the M1000 features sophisticated, processor-based signal conversion with accuracies of ± 0.3 percent.

The M1000 can be chosen for a broad spectrum of applications and the wide selection of liner and electrode materials provide maximum compatibility and minimum maintenance over a long operating period.

OPERATION

The operating principle of the electromagnetic flow meter is based on Faraday's law of magnetic induction: The voltage induced across any conductor, as it moves at right angles through a magnetic field, is proportional to the velocity of that conductor. The voltage induced within the fluid is measured by two diametrically opposed internally mounted electrodes. The induced signal voltage is proportional to the product of the magnetic flux density, the distance between the electrodes and the average flow velocity of the fluid.

ELECTRODES

When looking from the end of the meter into the inside bore, the two measuring electrodes are positioned at three o'clock and nine o'clock. As a conductive fluid flows through the magnetic field, a voltage is induced across the electrodes. This voltage is proportional to the average flow velocity of the fluid and is measured by the two electrodes. This induced voltage is then amplified and processed digitally by the converter to produce an accurate analog or digital signal. The signal can then be used to indicate flow rate and totalization or to communicate to remote sensors and controllers.

The M1000 Electromagnetic Flow Meter also has an "empty pipe" detection feature. This is accomplished with a third electrode positioned in the meter between twelve o'clock and one o'clock. If this electrode is not covered by fluid for a minimum of five-seconds, the meter will display an "empty pipe" condition. When the electrode again becomes covered with fluid, the error message will disappear and the meter will continue measuring.

SENSOR

The flow meter is a stainless steel tube lined with a non-conductive material. Outside the tube, two DC powered electromagnetic coils are positioned opposing each other. Perpendicular to these coils, two electrodes are inserted into the flow tube. Energized coils create a magnetic field across the whole diameter of the pipe. With a no moving parts, open flow tube design there is no pressure lost and practically no maintenance required



APPLICATION

The M1000 Electromagnetic Flow Meter has been specifically designed for industrial water/wastewater, machinery plants, vehicles and batching process applications. Available in sizes 1/4...20 inch (DN 6...500) and nominal pressures up to 1450 psi (100 bar), the meter is best suited for bidirectional flow measurements of fluid $> 5 \mu\text{S}/\text{cm}$ ($> 20 \mu\text{S}/\text{cm}$ for demineralized water). The transmitter can be integrally mounted to the sensor, or if necessary, mounted remotely. The transmitter is housed in a Type NEMA 4X (IP67) enclosure and the measuring pipes are lined with material approved for drinking water: KTW/DVGW, NSF/ANSI/CAN 61 and 372, WRAS, ACS. Several process connections are available, including DIN flanges, dairy pipe connections and TriClamp[®].

FEATURES

- Accuracy $\pm 0.3\%$
- Flow range 0.03...12 m/s
- Sizes 1/4 ...20 in. (6...500 DN)
- LCD display
- Power supply 92...275V AC, 9...36V DC
- RS-232, RS-485 and RS-422 with Modbus[®] RTU
Optional Modbus TCP/IP, M-Bus or HART
- Integrated data logger
- BEACON[®]/AquaCUE[®] connectivity



SPECIFICATIONS

NOTE: DN represents nominal diameter in mm.

Sensor Type II Specifications

The Sensor Type II is not only available in a number of different flange process connections (DIN, ANSI, JIS, AWWA) but also in a number of liners like hard rubber, soft rubber, PTFE, PFA or Halar. Available in sizes 1/4...20 inch (DN 6...500) and nominal pressures up to 1450 psi (100 bar), the Sensor Type II is best suited for a variety of applications in the industry and the water/waste water industry. Lined measuring pipes with materials approved for drinking water: KTW/DVGW, NSF/ANSI/CAN 61 and 372, WRAS, ACS.

Size	1/4...20 in. (DN 6...500)		
Process Connections	Flange: DIN, ANSI, JIS, AWWA		
Nominal Pressure	Up to 1450 psi (100 bar) (PED)		
Protection Class	IP 67, IP 68 optional		
Minimum Conductivity	5 μ S/cm (20 μ S/cm demineralized water)		
Liners	Hard/soft rubber	1 in. (DN 25) and up	32...176° F (0...80° C)
	PFA	1/4...3/8 in. (DN 6...10)	-40...302° F (-40...150° C)
	PTFE	1/2...20 in. (DN 15...500)	-40...302° F (-40...150° C)
Electrodes	Hastelloy C (Standard)	Platinum/Gold platinized	
	Tantalum	Platinum/Rhodium	
Body	Steel/stainless steel optional		
Grounding Rings	Stainless steel		

Process Connection Flange Remote Version in. (mm)

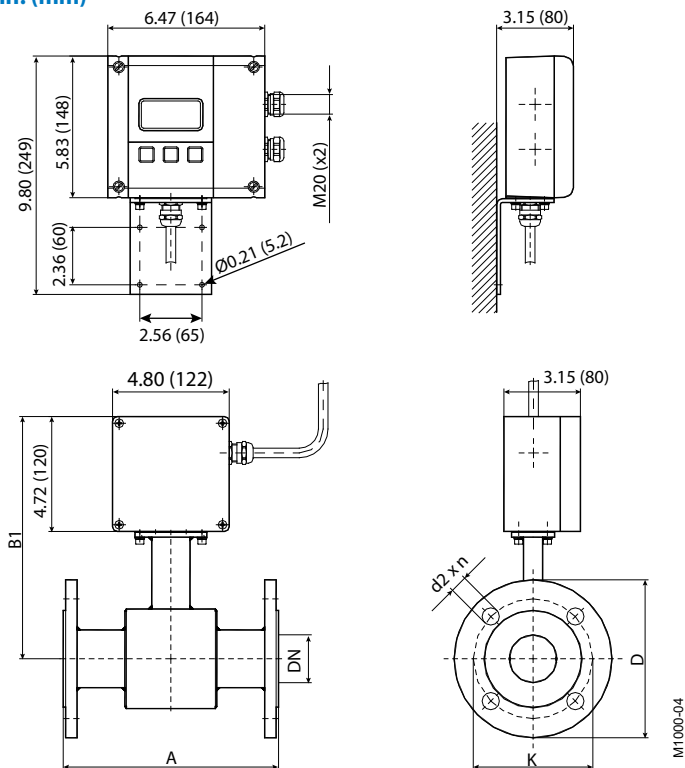

Process Connection Flange Mounted Version in. (mm)

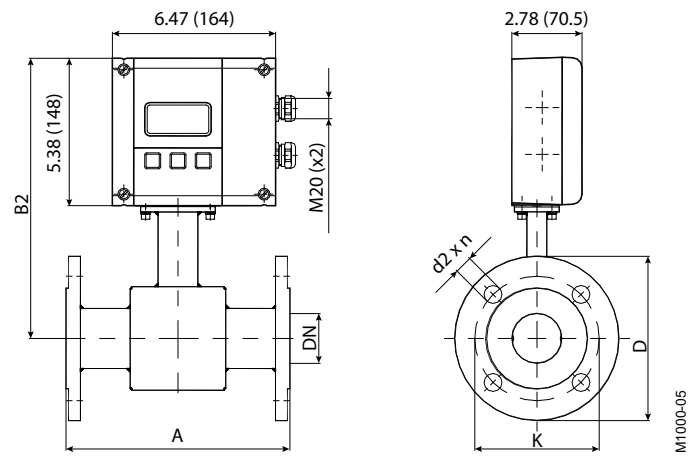

Flange ANSI Class 150, ASME B16.5

Size DN		A Standard		A ISO*		B1		B2		D		K		d2 x n	
inch	mm	inch	mm	inch	mm	inch	mm	inch	mm	inch	mm	inch	mm	inch	mm
1/4	6	6.7	170	—	—	9.0	228	10.1	256	3.5	89	2.4	61	0.6 x 4	16 x 4
5/16	8	6.7	170	—	—	9.0	228	10.1	256	3.5	89	2.4	61	0.6 x 4	16 x 4
3/8	10	6.7	170	—	—	9.0	228	10.1	256	3.5	89	2.4	61	0.6 x 4	16 x 4
1/2	15	6.7	170	7.9	200	9.4	238	10.5	266	3.5	89	2.4	61	0.6 x 4	16 x 4
3/4	20	6.7	170	7.9	200	9.4	238	10.5	266	3.9	99	2.8	71	0.6 x 4	16 x 4
1	25	8.9	225	7.9	200	9.4	238	10.5	266	4.3	109	3.1	79	0.6 x 4	16 x 4
1-1/4	32	8.9	225	7.9	200	10.0	253	11.1	281	4.6	117	3.5	89	0.6 x 4	16 x 4
1-1/2	40	8.9	225	7.9	200	10.0	253	11.1	281	5.0	127	3.9	99	0.6 x 4	16 x 4
2	50	8.9	225	7.9	200	10.0	253	11.1	281	6.0	152	4.8	122	0.8 x 4	19 x 4
2-1/2	65	11.0	280	7.9	200	10.7	271	11.8	299	7.0	178	5.5	140	0.8 x 4	19 x 4
3	80	11.0	280	7.9	200	10.7	271	11.8	299	7.5	191	6.0	152	0.8 x 4	19 x 4
4	100	11.0	280	9.8	250	10.9	278	12.0	306	9.0	229	7.5	191	0.8 x 8	19 x 8
5	125	15.7	400	9.8	250	11.7	298	12.8	326	10.0	254	8.5	216	0.9 x 8	22 x 8
6	150	15.7	400	11.8	300	12.2	310	13.3	338	11.0	279	9.5	241	0.9 x 8	22 x 8
8	200	15.7	400	13.8	350	13.3	338	14.4	366	13.5	343	11.8	300	0.9 x 8	22 x 8
10	250	19.7	500	17.7	450	14.3	362	15.4	390	16.0	406	14.3	363	1.0 x 12	25 x 12
12	300	19.7	500	19.7	500	16.7	425	17.8	453	19.0	483	17.0	432	1.0 x 12	25 x 12
14	350	19.7	500	21.7	550	17.7	450	18.8	478	21.0	533	18.8	478	1.1 x 12	28 x 12
16	400	23.6	600	23.6	600	18.7	475	19.8	503	23.5	597	21.3	541	1.1 x 16	28 x 16
18	450	23.6	600	25.6	—	19.7	500	20.8	528	25.0	635	22.8	579	1.3 x 16	32 x 16
20	500	23.6	600	25.6	—	20.7	525	21.8	553	27.5	699	25.0	635	1.3 x 20	32 x 20

Other sizes on request

IMPORTANT: ISO* sensor lay length according to ISO 20456

Flange ANSI Class 300, ASME B16.5

Size DN		A Standard		A ISO*		B1		B2		D		K		d2 x n	
inch	mm	inch	mm	inch	mm	inch	mm	inch	mm	inch	mm	inch	mm	inch	mm
1/2	15	6.7	170	7.9	200	9.4	238	10.5	266	3.8	95	2.6	67	0.6 x 4	16 x 4
3/4	20	6.7	170	7.9	200	9.4	238	10.5	266	4.6	117	3.3	83	0.8 x 4	19 x 4
1	25	8.9	225	7.9	200	9.4	238	10.5	266	4.9	124	3.5	89	0.8 x 4	19 x 4
1-1/4	32	8.9	225	7.9	200	10.0	253	11.1	281	5.3	133	3.9	99	0.8 x 4	19 x 4
1-1/2	40	8.9	225	7.9	200	10.0	253	11.1	281	6.1	155	4.5	114	0.9 x 4	22 x 4
2	50	8.9	225	7.9	200	10.0	253	11.1	281	6.5	165	5.0	127	0.8 x 8	19 x 8
2-1/2	65	11.0	280	7.9	200	10.7	271	11.8	299	7.5	191	5.9	149	0.9 x 8	22 x 8
3	80	11.0	280	7.9	200	10.7	271	11.8	299	8.3	210	6.6	168	0.9 x 8	22 x 8
4	100	11.0	280	9.8	250	10.9	278	12.0	306	10.0	254	7.9	200	0.9 x 8	22 x 8
5	125	15.7	400	9.8	250	11.7	298	12.8	326	11.0	279	9.3	235	0.9 x 8	22 x 8
6	150	15.7	400	11.8	300	12.2	310	13.3	338	12.5	318	10.6	270	0.9 x 12	22 x 12
8	200	15.7	400	13.8	350	13.3	338	14.4	366	15.0	381	13.0	330	1.0 x 12	25 x 12
10	250	19.7	500	17.7	450	14.3	362	15.4	390	17.5	445	15.3	387	1.1 x 16	28 x 16
12	300	19.7	500	19.7	500	16.7	425	17.8	453	20.5	521	17.8	451	1.3 x 16	32 x 16
14	350	19.7	500	21.7	550	17.7	450	18.8	478	23.0	584	20.3	514	1.3 x 20	32 x 20
16	400	23.6	600	23.6	600	18.7	475	19.8	503	25.5	648	22.5	572	1.4 x 20	35 x 20
18	450	23.6	600	25.6	—	19.7	500	20.8	528	28.0	711	24.8	629	1.4 x 24	35 x 24
20	500	23.6	600	25.6	—	20.7	525	21.8	553	30.5	775	27.0	686	1.4 x 24	35 x 24

Other sizes on request

IMPORTANT: ISO* sensor lay length according to ISO 20456

Flange EN 1092-1 / PN 10

Size DN		A Standard		A ISO*		B1		B2		D		K		d2 x n	
inch	mm	inch	mm	inch	mm	inch	mm	inch	mm	inch	mm	inch	mm	inch	mm
8	200	15.7	400	13.8	350	13.3	338	14.4	366	13.4	340	11.6	295	0.9 x 8	22 x 8
10	250	19.7	500	17.7	450	14.3	362	15.4	390	15.6	395	13.8	350	0.9 x 12	22 x 12
12	300	19.7	500	19.7	500	16.7	425	17.8	453	17.5	445	15.7	400	0.9 x 12	22 x 12
14	350	19.7	500	21.7	550	17.7	450	18.8	478	19.9	505	18.1	460	0.9 x 16	22 x 16
16	400	23.6	600	23.6	600	18.7	475	19.8	503	22.2	565	20.3	515	1.0 x 16	26 x 16
18	450	23.6	600	25.6	—	19.7	500	20.8	528	24.2	615	22.2	565	1.0 x 20	26 x 20
20	500	23.6	600	25.6	—	20.7	525	21.8	553	26.4	670	24.4	620	1.0 x 20	26 x 20

Other sizes on request

IMPORTANT: ISO* sensor lay length according to ISO 20456**Flange EN 1092-1 / PN 16**

Size DN		A Standard		A ISO*		B1		B2		D		K		d2 x n	
inch	mm	inch	mm	inch	mm	inch	mm	inch	mm	inch	mm	inch	mm	inch	mm
1/4	6	6.7	170	—	—	9.0	228	10.1	256	3.5	90	2.4	60	0.6 x 4	14 x 4
5/16	8	6.7	170	—	—	9.0	228	10.1	256	3.5	90	2.4	60	0.6 x 4	14 x 4
3/8	10	6.7	170	—	—	9.0	228	10.1	256	3.5	90	2.4	60	0.6 x 4	14 x 4
1/2	15	6.7	170	7.9	200	9.4	238	10.5	266	3.7	95	2.6	65	0.6 x 4	14 x 4
3/4	20	6.7	170	7.9	200	9.4	238	10.5	266	4.1	105	3.0	75	0.6 x 4	14 x 4
1	25	8.9	225	7.9	200	9.4	238	10.5	266	4.5	115	3.3	85	0.6 x 4	14 x 4
1-1/4	32	8.9	225	7.9	200	10.0	253	11.1	281	5.5	140	3.9	100	0.7 x 4	18 x 4
1-1/2	40	8.9	225	7.9	200	10.0	253	11.1	281	5.9	150	4.3	110	0.7 x 4	18 x 4
2	50	8.9	225	7.9	200	10.0	253	11.1	281	6.5	165	4.9	125	0.7 x 4	18 x 4
2-1/2	65	11.0	280	7.9	200	10.7	271	11.8	299	7.3	185	5.7	145	0.7 x 4	18 x 4
3	80	11.0	280	7.9	200	10.7	271	11.8	299	7.9	200	6.3	160	0.7 x 8	18 x 8
4	100	11.0	280	9.8	250	10.9	278	12.0	306	8.7	220	7.1	180	0.7 x 8	18 x 8
5	125	15.7	400	9.8	250	11.7	298	12.8	326	9.8	250	8.3	210	0.7 x 8	18 x 8
6	150	15.7	400	11.8	300	12.2	310	13.3	338	11.2	285	9.4	240	0.9 x 8	22 x 8
8	200	15.7	400	13.8	350	13.3	338	14.4	366	13.4	340	11.6	295	0.9 x 12	22 x 12
10	250	19.7	500	17.7	450	14.3	362	15.4	390	15.9	405	14.0	355	1.0 x 12	26 x 12
12	300	19.7	500	19.7	500	16.7	425	17.8	453	18.1	460	16.1	410	1.0 x 12	26 x 12
14	350	19.7	500	21.7	550	17.7	450	18.8	478	20.5	520	18.5	470	1.0 x 16	26 x 16
16	400	23.6	600	23.6	600	18.7	475	19.8	503	22.8	580	20.7	525	1.2 x 16	30 x 16
18	450	23.6	600	25.6	—	19.7	500	20.8	528	25.2	640	23.0	585	1.2 x 20	30 x 20
20	500	23.6	600	25.6	—	20.7	525	21.8	553	28.1	715	25.6	650	1.3 x 20	33 x 20

Other sizes on request

IMPORTANT: ISO* sensor lay length according to ISO 20456

Flange EN 1092-1 / PN 25

Size DN		A Standard		A ISO*		B1		B2		D		K		d2 x n	
inch	mm	inch	mm	inch	mm	inch	mm	inch	mm	inch	mm	inch	mm	inch	mm
1/2	15	6.7	170	7.9	200	9.4	238	10.5	266	3.7	95	2.6	65	0.6 x 4	14 x 4
3/4	20	6.7	170	7.9	200	9.4	238	10.5	266	4.1	105	3.0	75	0.6 x 4	14 x 4
1	25	8.9	225	7.9	200	9.4	238	10.5	266	4.5	115	3.3	85	0.6 x 4	14 x 4
1-1/4	32	8.9	225	7.9	200	10.0	253	11.1	281	5.5	140	3.9	100	0.7 x 4	18 x 4
1-1/2	40	8.9	225	7.9	200	10.0	253	11.1	281	5.9	150	4.3	110	0.7 x 4	18 x 4
2	50	8.9	225	7.9	200	10.0	253	11.1	281	6.5	165	4.9	125	0.7 x 4	18 x 4
2-1/2	65	11.0	280	7.9	200	10.7	271	11.8	299	7.3	185	5.7	145	0.7 x 4	18 x 8
3	80	11.0	280	7.9	200	10.7	271	11.8	299	7.9	200	6.3	160	0.7 x 8	18 x 8
4	100	11.0	280	9.8	250	10.9	278	12.0	306	9.3	235	7.5	190	0.9 x 8	22 x 8
5	125	15.7	400	9.8	250	11.7	298	12.8	326	10.6	270	8.7	220	1.0 x 8	26 x 8
6	150	15.7	400	11.8	300	12.2	310	13.3	338	11.8	300	9.8	250	1.0 x 8	26 x 8
8	200	15.7	400	13.8	350	13.3	338	14.4	366	14.2	360	12.2	310	1.0 x 8	26 x 12
10	250	19.7	500	17.7	450	14.3	362	15.4	390	16.7	425	14.6	370	1.2 x 12	30 x 12
12	300	19.7	500	19.7	500	16.7	425	17.8	453	19.1	485	16.9	430	1.2 x 12	30 x 16
14	350	19.7	500	21.7	550	17.7	450	18.8	478	21.9	555	19.3	490	1.3 x 16	33 x 16
16	400	23.6	600	23.6	600	18.7	475	19.8	503	24.4	620	21.7	550	1.4 x 16	36 x 16
18	450	23.6	600	25.6	—	19.7	500	20.8	528	26.4	670	23.6	600	1.4 x 20	36 x 20
20	500	23.6	600	25.6	—	20.7	525	21.8	553	28.7	730	26.0	660	1.4 x 20	36 x 20

Other sizes on request

IMPORTANT: ISO* sensor lay length according to ISO 20456

Flange EN 1092-1 / PN 40

Size DN		A Standard		A ISO*		B1		B2		D		K		d2 x n	
inch	mm	inch	mm	inch	mm	inch	mm	inch	mm	inch	mm	inch	mm	inch	mm
1/2	15	6.7	170	7.9	200	9.4	238	10.5	266	3.7	95	2.6	65	0.6 x 4	14 x 4
3/4	20	6.7	170	7.9	200	9.4	238	10.5	266	4.1	105	3.0	75	0.6 x 4	14 x 4
1	25	8.9	225	7.9	200	9.4	238	10.5	266	4.5	115	3.3	85	0.6 x 4	14 x 4
1-1/4	32	8.9	225	7.9	200	10.0	253	11.1	281	5.5	140	3.9	100	0.7 x 4	18 x 4
1-1/2	40	8.9	225	7.9	200	10.0	253	11.1	281	5.9	150	4.3	110	0.7 x 4	18 x 4
2	50	8.9	225	7.9	200	10.0	253	11.1	281	6.5	165	4.9	125	0.7 x 4	18 x 4
2-1/2	65	11.0	280	7.9	200	10.7	271	11.8	299	7.3	185	5.7	145	0.7 x 4	18 x 8
3	80	11.0	280	7.9	200	10.7	271	11.8	299	7.9	200	6.3	160	0.7 x 8	18 x 8
4	100	11.0	280	9.8	250	10.9	278	12.0	306	9.3	235	7.5	190	0.9 x 8	22 x 8
5	125	15.7	400	9.8	250	11.7	298	12.8	326	10.6	270	8.7	220	1.0 x 8	26 x 8
6	150	15.7	400	11.8	300	12.2	310	13.3	338	11.8	300	9.8	250	1.0 x 8	26 x 8
8	200	15.7	400	13.8	350	13.3	338	14.4	366	14.8	375	12.6	320	1.2 x 8	30 x 12
10	250	19.7	500	17.7	450	14.3	362	15.4	390	17.7	450	15.2	385	1.3 x 12	33 x 12
12	300	19.7	500	19.7	500	16.7	425	17.8	453	20.3	515	17.7	450	1.3 x 12	33 x 16
14	350	19.7	500	21.7	550	17.7	450	18.8	478	22.8	580	20.1	510	1.4 x 16	36 x 16
16	400	23.6	600	23.6	600	18.7	475	19.8	503	26.0	660	23.0	585	1.5 x 16	39 x 16
18	450	23.6	600	25.6	—	19.7	500	20.8	528	27.0	685	24.0	610	1.5 x 20	39 x 20
20	500	23.6	600	25.6	—	20.7	525	21.8	553	29.7	755	26.4	670	1.7 x 20	42 x 20

Other sizes on request

IMPORTANT: ISO* sensor lay length according to ISO 20456

Sensor with Sanitary Process Connections Specifications

The sensor model is available with Tri-Clamp, DIN 11851, ISO2852 or BS4825 process connections. The sanitary sensor is delivered in a stainless steel housing and with PTFE lining.

Size	3/8...4 in. (DN 10...100)		
Process Connections	Tri-Clamp®, DIN 11851, ISO2852, BS4825 and customer specified.		
Nominal Pressure	Tri-Clamp connection	145 psi (10 bar)	
	DIN 11851 connection	230 psi (16 bar)	
Protection Class	IP 67, IP 68 optional		
Minimum Conductivity	5 µS/cm(20 µS/cm demineralized water)		
Liners	PTFE	-40...302° F (-40...150° C)	
Electrodes	Hastelloy C (Standard)	Platinum/Gold Platinized	
	Tantalum	Platinum/Rhodium	
Body	Stainless steel		
Overall Length	Tri-Clamp connection	3/8...2 in. (DN 10...50)	5.71 in. (145 mm)
		2-1/2...4 in. (DN 65...100)	7.87 in. (200 mm)
	DIN 11851 connection	3/8...3/4 in. (DN 10...20)	6.69 in. (170 mm)
		1...2 in. (DN 25...50)	8.86 in. (225 mm)
		2-1/2...4 in. (DN 65...100)	11.02 in. (280 mm)

Tri-Clamp Connection Remote Version
in. (mm)

DIN 11851 Connection Remote Version
in. (mm)

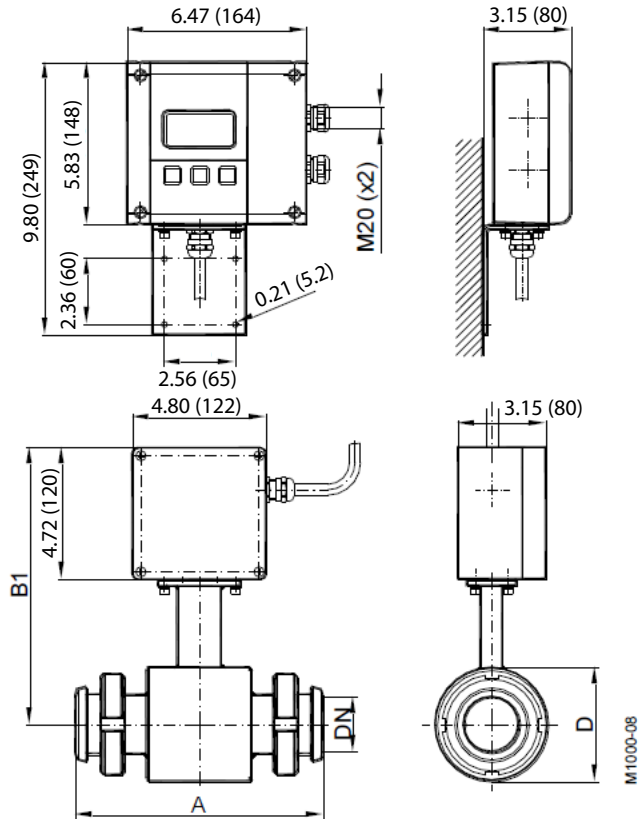
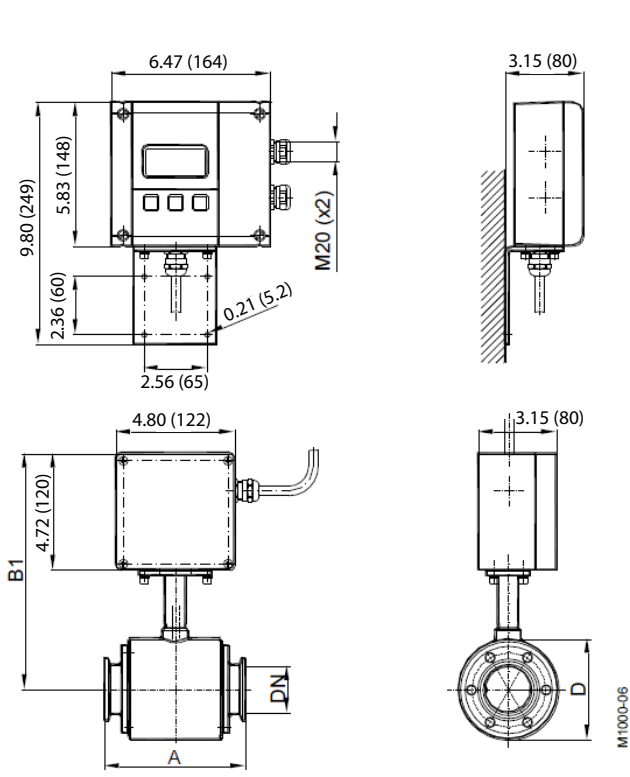

Tri-Clamp Connection Mounted Version
in. (mm)

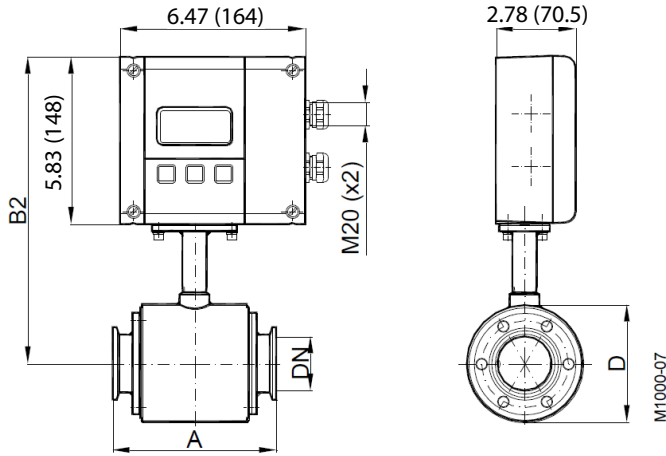

DIN 11851 Connection Mounted Version
in. (mm)

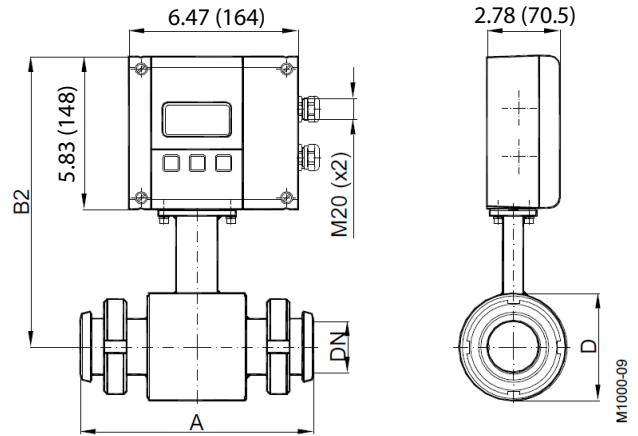

Tri-Clamp					
Size		A	B1	B2	D
Inches	DN	in. (mm)	in. (mm)	in. (mm)	in. (mm)
3/8 in.	10	5.71 (145)	8.98 (228)	10.08 (256)	2.91 (74)
1/2 in.	15	5.71 (145)	8.98 (228)	10.08 (256)	2.91 (74)
3/4 in.	20	5.71 (145)	8.98 (228)	10.08 (256)	2.91 (74)
1 in.	25	5.71 (145)	8.98 (228)	10.08 (256)	2.91 (74)
1-1/2 in.	40	5.71 (145)	9.37 (238)	10.47 (266)	3.70 (94)
2 in.	50	5.71 (145)	9.57 (243)	10.67 (271)	4.09 (104)
2-1/2 in.	65	7.87 (200)	10.08 (256)	11.18 (284)	5.08 (129)
3 in.	80	7.87 (200)	10.28 (261)	11.38 (289)	5.51 (140)
4 in.	100	7.87 (200)	10.59 (269)	11.69 (297)	6.14 (156)
Nominal Pressure 145 psi (10 bar)					

DIN 11851					
Size		A	B1	B2	D
Inches	DN	in. (mm)	in. (mm)	in. (mm)	in. (mm)
3/8 in.	10	6.69 (170)	9.37 (238)	10.47 (266)	2.91 (74)
1/2 in.	15	6.69 (170)	9.37 (238)	10.47 (266)	2.91 (74)
3/4 in.	20	6.69 (170)	9.37 (238)	10.47 (266)	2.91 (74)
1 in.	25	8.86 (225)	9.37 (238)	10.47 (266)	2.91 (74)
1-1/4 in.	32	8.86 (225)	9.57 (243)	10.67 (271)	3.31 (84)
1-1/2 in.	40	8.86 (225)	9.76 (248)	10.87 (276)	3.70 (94)
2 in.	50	8.86 (225)	9.96 (253)	11.06 (281)	4.09 (104)
2-1/2 in.	65	11.02 (280)	10.47 (266)	11.57 (294)	5.08 (129)
3 in.	80	11.02 (280)	10.67 (271)	11.77 (299)	5.51 (140)
4 in.	100	11.02 (280)	10.98 (279)	12.09 (307)	6.14 (156)
Nominal Pressure 232 psi (16 bar)					

Tri-Clamp Connection Standards BS4825/ISO2852

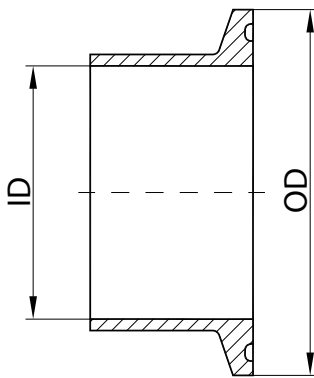

BS4825					ISO2852				
Size	OD		ID		Size	OD		ID	
in.	in.	mm	in.	mm	DN	in.	mm	in.	mm
—	—	—	—	—	10	0.98	25.0	0.55	14.0
1/2	0.98	25.0	0.37	9.4	15	1.99	50.5	0.71	18.1
3/4	0.98	25.0	0.62	15.75	20	1.99	50.5	0.90	22.9
1	1.99	50.5	0.87	22.1	25	1.99	50.5	1.13	28.7
—	—	—	—	—	32	2.52	64.0	1.51	38.4
1-1/2	1.99	50.5	1.37	34.8	40	2.52	64.0	1.74	44.3
2	2.52	64.0	1.87	47.5	50	3.05	77.5	2.22	56.3
2-1/2	3.05	77.5	2.37	60.2	65	3.58	91.0	2.84	72.1
3	3.58	91.0	2.87	72.9	80	4.17	106.0	3.32	84.3
4	4.69	119.0	3.83	97.4	100	5.12	130.0	4.32	109.7
Nominal Pressure 145 psi (10 bar)									

Sensor Type III Specifications

Thanks to its very short lay length, the Sensor Type III is often the right alternative. Delivered with a PTFE liner, the Sensor Type III has a standard nominal pressure of 580 psi (40 bar).

Size	1...4 in. (DN 25...100)	
Process Connections	Wafer connection, (intermediate flange mounting)	
Nominal Pressure	580 psi (40 bar)	
Protective Class	IP 67, IP 68 optional	
Minimum Conductivity	5 μ S/cm(20 μ S/cm demineralized water)	
Liner	PTFE	-40...302° F (-40...150° C)
Electrodes	Hastelloy C (Standard) Tantalum	Platinum/Gold platinized Platinum/Rhodium
Body	Steel/stainless steel optional	
Grounding Rings	Stainless steel	
Overall Length	1...2 in. (DN 25...50)	3.94 in. (100 mm)
	2-1/2...4 in. (DN 65...100)	5.91 in. (150 mm)

Process Connection Wafer Remote Version in. (mm)

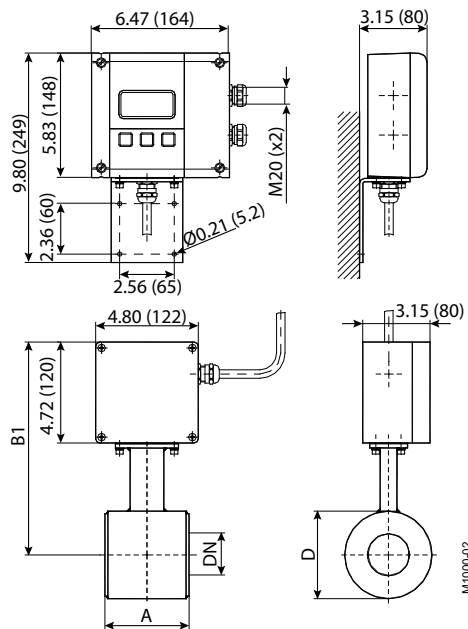

Process Connection Wafer Mounted Version in. (mm)

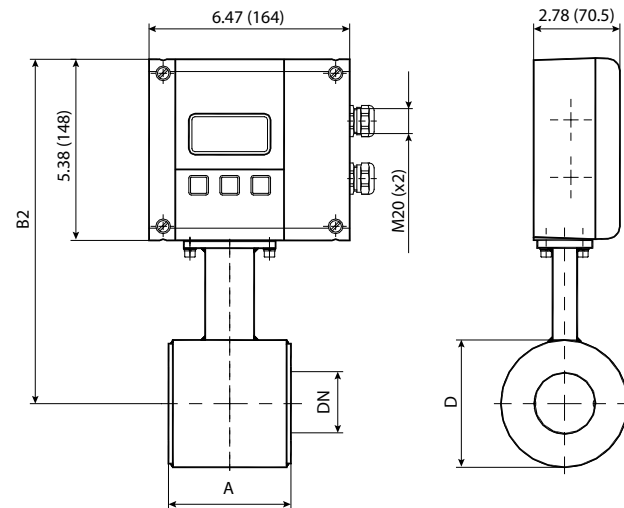

Size		A in. (mm)	B1 in. (mm)	B2 in. (mm)	D in. (mm)
Inches	DN				
1 in.	25	3.94 (100)	9.37 (238)	10.47 (266)	2.91 (74)
1-1/4 in.	32	3.94 (100)	9.57 (243)	10.67 (271)	3.31 (84)
1-1/2 in.	40	3.94 (100)	9.76 (248)	10.87 (276)	3.70 (94)
2 in.	50	3.94 (100)	9.96 (253)	11.06 (281)	4.09 (104)
2-1/2 in.	65	5.91 (150)	10.47 (266)	11.57 (294)	5.08 (129)
3 in.	80	5.91 (150)	10.67 (271)	11.77 (299)	5.51 (140)
4 in.	100	5.91 (150)	10.98 (279)	12.09 (307)	6.14 (156)

Nominal Pressure 580 psi (40 bar)

Transmitter Type ModMAG M1000 Specifications

Type	ModMAG M1000
Auxiliary Power	92...275V AC (50 / 60 Hz), 13VA optional 9...36V DC, 4 W
Analog Output	0/4...20 mA, $\leq 800 \text{ Ohm}$ / 0...10 mA Flow direction is displayed via separate status output
Digital Outputs	2 open collectors, passive 32V DC, 0...100 Hz 100 mA, 100...10,000 Hz 20 mA, optional active Pulse, status, error messages Absolute Digital Encoded output for connectivity to AquaCUE or BEACON cellular endpoints
Digital Inputs	Totalizers and preselectors reset Positive Zero Return
Frequency Output	10 kHz
Empty Pipe Detection	Separate electrode for empty pipe detection / field-tunable for optimal performance
Configuration	3 external buttons
Interfaces	RS232, RS422, RS485, ModBus RTU, Optional ModBus TCP/IP, M-Bus or HART
Measuring Range	0.10...39.37 ft/s (0.03...12 m/s)
Measuring Accuracy	0.3% of reading $\pm 0.08 \text{ in./s}$ (2 mm/s)
Reproducibility	0.1%
Flow Direction	Uni-directional and bi-directional
Pulse Length	Configurable up to 2000 msec
Outputs	Short-circuit-proof and galvanically separated
Low Flow Cutoff	0...10%
Display	Graphical LCD 64 × 128, backlight, actual flow rate, totalizers, status display
Housing	Powder-coated aluminum die casting
Mounting	Sensor or remote wall mount
Protective Class	IP 67
Cable Insert	Supply and signal cables 2 × M20
Remote Signal Cable	Up to 164 ft / 50 m
Coil Power	Pulsed DC
Altitude	8202 ft (2500 m)
Ambient Temperature	-4...140° F (-20...60° C)
Humidity	90% R.H. max
Approvals	NSF/ANSI/CAN 61 and 372 Listed: Models with hard rubber liner 4 in. size and up; PTFE liner, all sizes WRAS/ACS: WRAS (hard rubber), ACS (PTFE)
Pollution Degree	2
Installation Category	II
Units of Measure	Gallons, ounces, MGD, liters, cubic meters, cubic feet, imperial gallon, barrel, hectoliter and acre-feet

ModMAG M1000 Transmitter in. (mm)

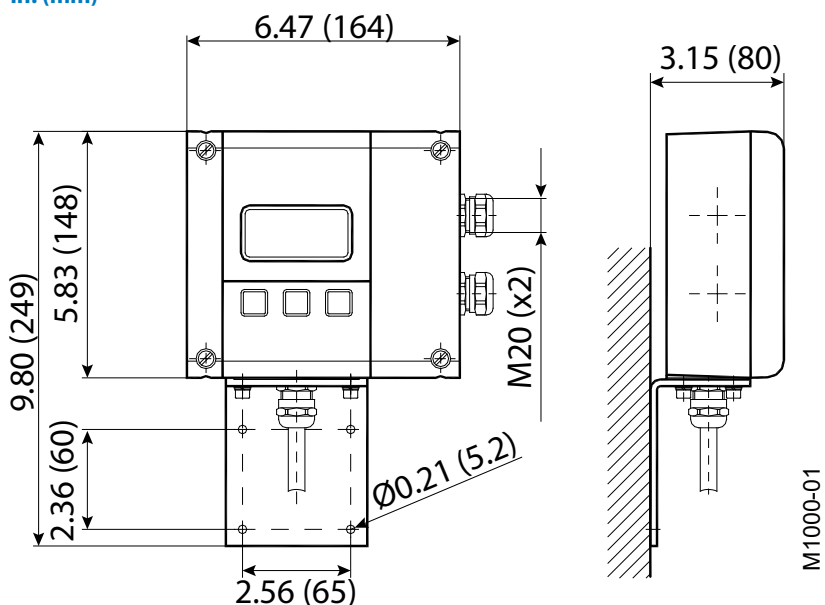

SIZE SELECTION

Size		Flow Range	
Inches	DN	US	Metric
1/4	6	0.0134...5.4 GPM	0.051...20.4 l/min
3/10	8	0.0239...9.6 GPM	0.090...36.2 l/min
3/8	10	0.0373...14.9 GPM	0.141...57 l/min
1/2	15	0.084...33.6 GPM	0.318...127 l/min
3/4	20	0.149...60 GPM	0.57...226 l/min
1	25	0.233...93 GPM	0.88...353 l/min
1 1/4	32	0.382...153 GPM	1.45...579 l/min
1 1/2	40	0.60...239 GPM	2.26...905 l/min
2	50	0.93...373 GPM	3.53...1414 l/min
2 1/2	65	1.58...631 GPM	0.358...143 m ³ /h
3	80	2.39...956 GPM	0.54...217 m ³ /h
4	100	3.73...1494 GPM	0.85...339 m ³ /h
5	125	5.8...2334 GPM	1.33...530 m ³ /h
6	150	8.4...3361 GPM	1.91...763 m ³ /h
8	200	14.9...5975 GPM	3.39...1357 m ³ /h
10	250	23.3...9336 GPM	5.3...2121 m ³ /h
12	300	33.6...13,444 GPM	7.6...3054 m ³ /h
14	350	45.7...18,299 GPM	10.4...4156 m ³ /h
16	400	60...23,901 GPM	13.6...5429 m ³ /h
18	450	76...30,250 GPM	17.2...6870 m ³ /h
20	500	93...37,345 GPM	21.2...8482 m ³ /h

PART NUMBER CONSTRUCTION

ModMAG®
Model M1000

Model Code

	M	A	H	C	D	B	A	J
General area								
<u>Size</u>								
DN 6	1/4 IN.	liner PFA / 304 SST	002					
DN 8	5/16 IN.	liner PFA / 304 SST	003					
DN 10	3/8 IN.	liner PFA / 304 SST	004					
DN 15	1/2 IN.		005					
DN 20	3/4 IN.		007					
DN 25	1 IN.		010					
DN 32	1-1/4 IN.		012					
DN 40	1-1/2 IN.		015					
DN 50	2 IN.		020					
DN 65	2-1/2 IN.		025					
DN 80	3 IN.		030					
DN 100	4 IN.		040					
DN 125	5 IN.		050					
DN 150	6 IN.		060					
DN 200	8 IN.		080					
DN 250	10 IN.		100					
DN 300	12 IN.		120					
DN 350	14 IN.		140					
DN 400	16 IN.		160					
DN 450	18 IN.		180					
DN 500	20 IN.		200					
<u>Process connection</u>								
EN 1092-1 PN 40			FEE					
EN 1092-1 PN 25			FED					
EN 1092-1 PN 16			FEC					
EN 1092-1 PN 10			FEB					
ASME Class 300			FAB					
ASME Class 150			FAA					
TriClamp ISO 2852			TAE					
TriClamp BS 4825			TAB					
Threads DIN 11851			DAA					
Welder			WAA					
<u>Range and Housing material</u>								
Carbon Steel (Standard)			C1					
Carbon Steel w/ CSM Paint			C2					
304 Stainless Steel Connection / Housing			S3					
316 Stainless Steel Connection / Housing			S7					
Carbon Steel Process Connections (Std. Paint) / 316 Stainless Steel Housing			C4					
<u>Linear Material</u>								
Hard Rubber			H					
PTFE for sizes > DN10 (3/8 IN.)			P					
PFA DN 6...DN 10 (1/4...3/8 IN.) with PFA liner			A					
<u>Electrodes / Measuring, Empty pipe, Grounding</u>								
Hastelloy C-22 (Standard / Measuring Empty pipe & Grounding)			A					
Hastelloy C-22 (Standard / Measuring & Empty pipe)			J					
AlSi 316/L 4571			B					
Tantalum			C					
Platinum/Rhodium			D					
<u>Grounding rings</u>								
No Grounding Rings			X					
304 Stainless Steel Grounding Rings			A					
316 Stainless Steel Grounding Rings			B					
<u>Motor / Lay Length</u>								
Standard			S					
ISO 20456			O					
<u>Transmitters</u>								
Sensor-Mounted; Local Display; Aluminum Encl.; IP67			SA					
Sensor-Mounted; Local Display; Stainless Steel Encl.; IP67			SB					
Sensor-Mounted; No Display/Blind; Aluminum Encl.; IP67			SC					
Remote-Mounted; Local Display; Aluminum Encl.; IP67; Incl. Mounting Bracket			RA					
Remote-Mounted; Local Display; Stainless Steel Encl.; IP67; Incl. Mounting Bracket			RB					
Remote-Mounted; No Display/Blind; Aluminum Encl.; IP67; Incl. Mounting Bracket			RC					
<u>Power Supply Hardware</u>								
110/220V AC			AA					
9...36V DC			AB					
<u>Junction Box (for remote mounted version)</u>								
Aluminum Enclosure; IP67 (Type 6/4X) Rating			A					
Aluminum Enclosure; IP68 (Type 6P) Rating			B					
Stainless Steel Enclosure; IP67 (Type 6/4X) Rating			C					
Stainless Steel Enclosure; IP68 (Type 6P) Rating			D					
None Used for "Sensor-Mounted" Transmitters Configuration			X					
<u>Remote Cable Length (for remote mounted version)</u>								
15 ft. 5 m			MA					
30 ft. 10 m			MB					
50 ft. 15 m			MC					
65 ft. 20 m			MD					
80 ft. 25 m			ME					
100 ft. 30 m			MF					
115 ft. 35 m			MG					
130 ft. 40 m			MH					
150 ft. 45 m			MI					
165 ft. 50 m			MK					
None Used for "Sensor-Mounted" Transmitters Configuration			WW					
<u>Input/Output Channel</u>								
Standard Input/Output				D	B	A		
<u>Communications</u>								
Standard Communication (RS232/RS485 Modbus RTU)							R	
HART							P	
Modbus TCP/IP							G	
M-Bus wired							M	
<u>Wiring Method</u>								
Twist Tight; 5 ft. (1.52 m)								TF
Twist Tight; 10 ft. (3.05 m)								TH
Twist Tight; 25 ft. (7.62 m)								TJ
Twist Tight; 75 ft. (22.86 m)								TK
None No Endpoint (Standard)								XX
<u>Programming</u>								
Gallons/gallons per minute (North America Standard)								NA
Gallons/cubic feet per minute								NC
Gallons/cubic meters per second								ND
Cubic Meters/gallons per minute								NE
Cubic Feet/gallons per minute								NJ
Cubic Feet/cubic feet per minute								NK
Cubic Feet/cubic meters per hour								NL
Liters/gallons per minute								NM
Million Gallons/gallons per minute								NS
Gallons/millions gallons per day								NT
Acre Feet/gallons per minute								NU
Second-Foot Day/cubic feet per second								NV
Standard (Default Metric units based on size)								EA
m ³ /s and m ³								EB
m ³ /min and m ³								EC
m ³ /h and m ³								ED
L/s and L								EE
L/min and L								EF
L/h and L								EG
<u>Testion & Tagging</u>								
0.3% 3-Point Calibration; Factory (Standard)								F
0.3% 3-Point Calibration; Factory / Stainless steel Tag								S
3rd Party Calibrated								3
3rd Party Calibrated w/ Stainless Steel Tag								T
State of Kansas Certified (North America only)								K

Control. Manage. Optimize.

ModMAG is a registered trademark of Badger Meter, Inc. Other trademarks appearing in this document are the property of their respective entities. Due to continuous research, product improvements and enhancements, Badger Meter reserves the right to change product or system specifications without notice, except to the extent an outstanding contractual obligation exists. © 2022 Badger Meter, Inc. All rights reserved.

www.badgermeter.com